

Kobelco SK380SRLC (with Movax SG-60)

Excavator	Kobelco SK380SRLC
Engine Type	HINO J08 EYD Tier IV
Rated Power (ISO 9249: with fan)	188 kW @ 2100 rpm
Rated Power (ISO 14396: without fan)	200 kW @ 2100 rpm
Max. Torque (ISO 9249: with fan)	989 Nm @ 1600 rpm
Max. Torque (ISO 14396: without fan)	1017 Nm @ 1600 rpm
Monoboom Length	6.2 m
Arm Length	3.1 m
Height & Slew Restrictor	XWatch XW5
Ground Bearing Pressure	53 kN/m ²
Transport weight ^a	38.2 tonnes
Operating Weight (approx.) ^b	41 - 45 tonnes

^a Transport weight = excavator + counterweight & boom (excludes attachment)

^b Operating weight = excavator + counterweight & boom + attachment

Dimensions	(mm)
(A) Overall length	9980
(B) Overall height (to top of boom)	3300
(C) Overall width	3400
(D) Overall height (to top of handrail)	3380
(D') Overall height (to top of cab)	3350
(E) Ground clearance of rear end*	1160
(F) Ground clearance*	500
(G) Tall swing radius	1900
(G') Distance from centre of swing to rear end	1900
(H) Tumbler distance	4050
(I) Overall length of crawler	4960
(J) Track gauge	2590
(K) Show width	800
(L) Overall width of upper structure	3180

*Not including height of shoe lug

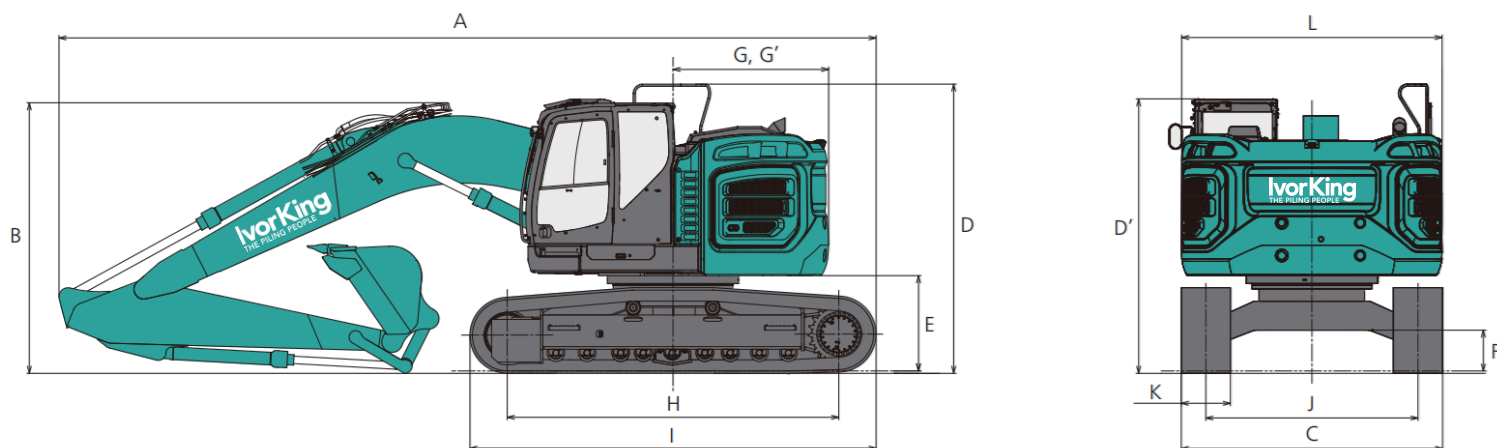

Kobelco SK380SRLC

Working Ranges

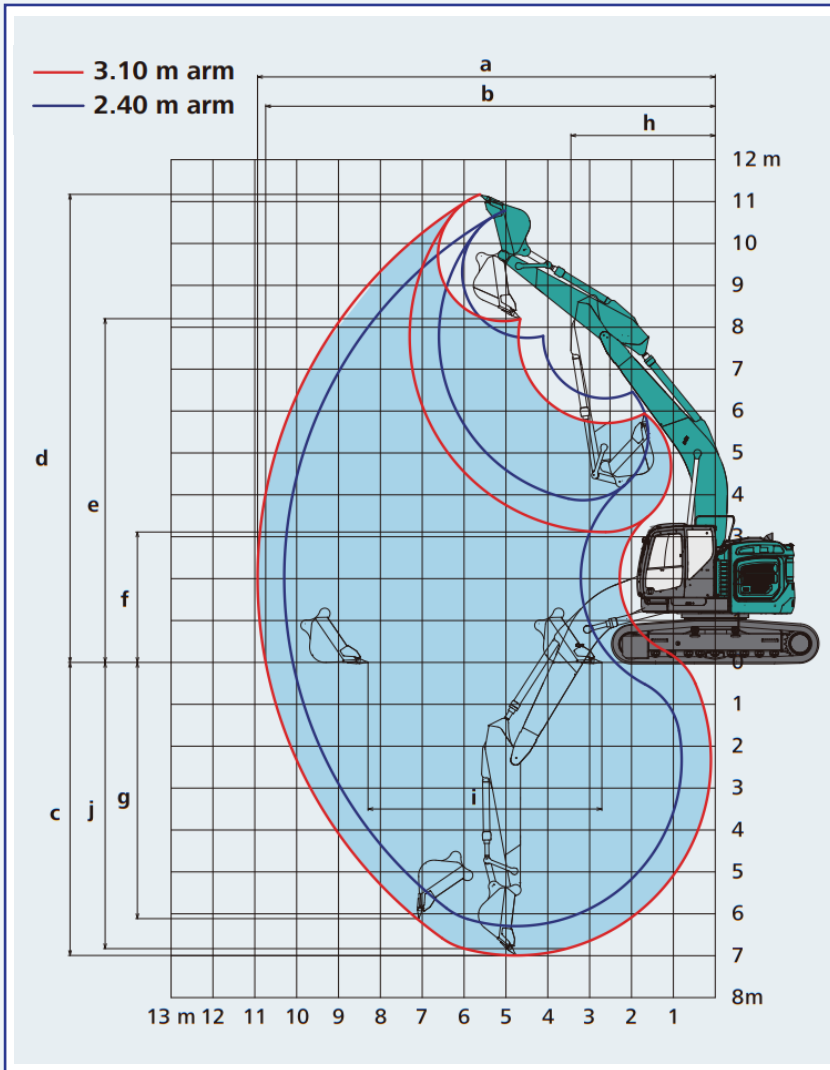

6.2m Boom with 3.1m Standard Arm

(a) Max digging reach	10.93m
(b) Max. reach at ground level	10.74m
(c) Max. digging depth	6.99m
(d) Max. digging height	11.17m
(e) Max. dumping clearance	8.15m
(f) Min. dumping clearance	3.11m
(g) Max. vertical wall	6.11m
(h) Max. swing radius	3.45m
(i) Horizontal digging stroke at ground level	5.59m
(j) Digging depth for 2.4 m (8')	6.83m
Bucket capacity ISO heaped	1.2m ³
Bucket digging force	189/208kN*
Arm crowding force	126/139kN*

*Power Boost Engaged

Quick Hitch

Strickland S-Lock Coupler

SWL: 30T



Weight: 1071 kg

Min. Range: 537 mm
Max. Range: 590 mm
Diameter of bar: Ø100 mm

Lifting Capacities

- Notes:**
- Lift capacities are in compliance with ISO 10567
 - Arm top defined as lift point
 - * Denotes lift capacities limited by hydraulic capacity rather than tipping load
 - The nominal loads do not exceed 87% of the hydraulic capacity or 75% of the capacity of the swing.
 - 0m = Ground level
 - Lift capacities are based on machine standing on level, firm and uniform ground
- NB: Weight of all accessories must be deducted from the above lift capacities

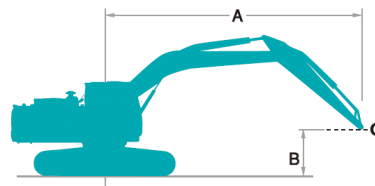

A: Reach from swing centreline to top arm
B: Arm top height above/below ground
C: Lift point



Rating over front



Rating side or 360 degrees

Unit: kg

Conditions	Load point height (m)	Load radius										Max. Reach		
		3.0 m		4.5 m		6.0 m		7.5 m		9.0 m		metre		
Boom 7.0 m Arm 3.45 m	9.0					*5380	*5380					*4790	*4790	6.10m
	7.5					*7420	*7420	*4530	*4530			*4240	*4240	7.53m
	6.0					*7960	*7960	*7600	5960			*4030	*4030	8.45m
	4.5	*16910	*16910	*11300	*11300	*9180	8170	*8110	5770	*4280	4250	*3990	*3990	9.03m
	3.0			*14640	11590	*10700	7640	*8860	5500	*6770	4140	*4090	3910	9.31m
	1.5			*17010	10690	*12030	7180	9070	5250	6910	4020	*4330	3800	9.35m
	0			*17670	10320	12390	6870	8860	5070	*6450	3940	*4770	3860	9.13m
	-1.5	*11420	*11420	*17140	10250	12250	6750	8770	4990			*5530	4150	8.64m
	-3.0	*18020	*18020	*15650	10370	*11810	6790	8840	5050			*6960	4800	7.82m
	-4.5	*17300	*17300	*12830	10690	*9480	7040					*8160	6290	6.54m

Kobelco SK380SRLC

Movax SG-60 Pile Driver

Technical Data	SG-60
Weight (excl. adapter)	2550 - 2850 kg
Width	1193 mm
Height	2550 mm
Depth	1210 - 1585 mm
Centrifugal force. Max.	600 kN
Eccentric moment	6.1 kgm
Engine power Min.	160 kW
Frequency	2300 - 3000 rpm
Pressure Setting	350 Bar
Return pressure. Max	5 Bar
Swing angle	± 360°
Tilt angle	± 30°
Clearance to centre line of pile	800 mm



Suitable Pile Types & Dimensions	
Sheet pile (width)	400 - 1200 mm
Sheet pile (depth)	265 mm
H-beam minimum size	H100 - H500
Timber pile	Ø 160 - 420 mm
Tubular pile, tubes	Up to 762 mm
	Length & Weight
	8 m / 2300 kg
	12 m / 1600 kg
	16 m / 1200 kg

Movax DH-25 Impact Hammer

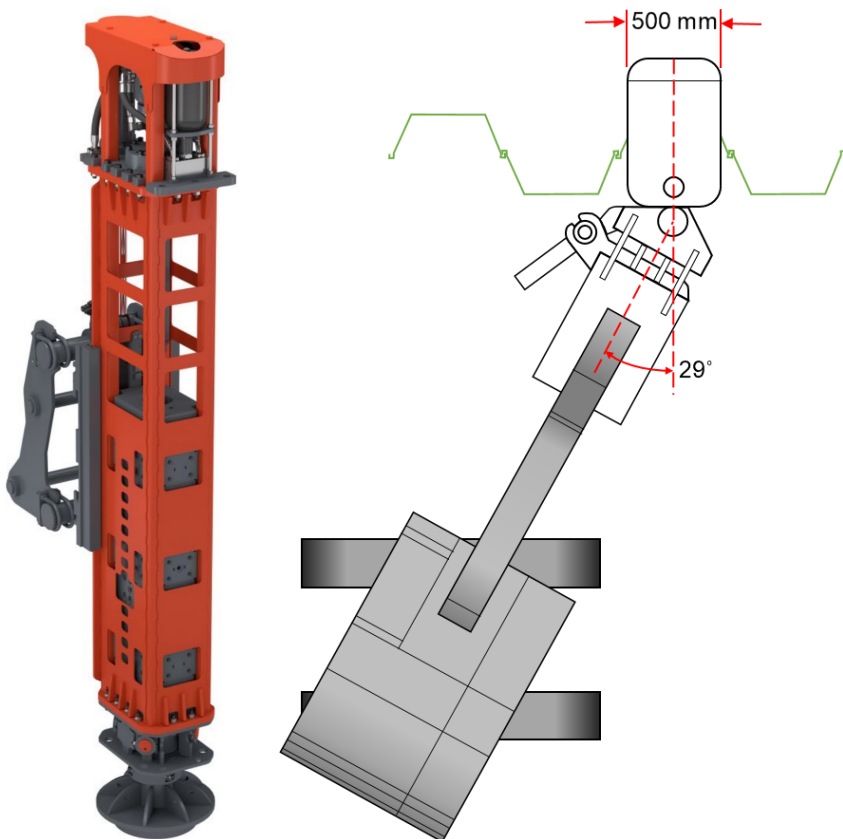

Technical Data	DH-25
Weight (inc. adapter, driving cap with tilt + rotation)	5450 kg
Transport width	1200 mm
Transport depth	1870 mm
Height	5100 mm
Blows per minute (max.)	100
Energy per blow	2039 kg/m
Drop height (max.)	1200 mm
Operating pressure	200 bar
Weight of ram	2000 kg
Rotation angle	+/- 29°
Tilt angle	+/- 15°

Kobelco SK380SRLC

Multi-Tool Piling Leader MPL-300

Technical Data		MPL-300
Weight	(without adapter & tool)	4000 - 4500 kg
Height		15.0 m
Forward inclination		20°
Backward inclination		20°
Tilt		8°
Rotation (optional)		60 - 90°
Winches	Main winch line pull	57 kN
	Aux winch line pull	25 kN
Crowd system	pull down force	57 / 114 kN
	extraction force	57 / 171 kN
Transport length		8600 mm
Transport width		1800 mm
Transport height		2000 mm
Transport weight		4000 - 5000 kg

Rotary drive for CFA RHP-5

Technical Data		RHP-5
Total weight		1400 kg
Torque (max.)		50 kNm
Drilling speed		0-50 rpm
Oil flow		250 l/min
Maximum pressure		320 bar
Pre-augering	Depth	12.0 m
	Hole diameter	300 - 600 mm
CFA	Depth	12.0 m
	Hole diameter	300 - 600 mm

