

## Movax Piling Rig

## Doosan DX255 + SG/SP-50

Excavator	Doosan DX255
Engine Type	Doosan DL006
Rated Power	129 kW @ 1900 rpm
Maximum Torque	765 Nm @ 1400 rpm
Monoboom Length	5.90 m
Arm Length	3.00 m
Ground Bearing Pressure	225 kN/m <sup>2</sup>
Transport weight <sup>a</sup>	24.6 tonnes
Operating Weight (approx.) <sup>b</sup>	25 - 28 tonnes

<sup>a</sup> Transport weight = excavator + counterweight & boom (excludes attachment)

<sup>b</sup> Operating weight = excavator + counterweight & boom + attachment

Dimensions	(mm)
(A) Overall width of upper structure	2710
(B) Overall width of cabin	1010
(C) Overall height of cabin	2970
(D) Tail swing radius	2995
(E) Overall height	3100
(F) Clearance under counterweight	1110
(G) Ground clearance	450
(H) Tumbler distance	3835
(I) Track length	4625
Track gauge (standard)	2600
(K) Track shoe width	800
(L) Overall length	10055
(M) Overall width (standard track)	3400

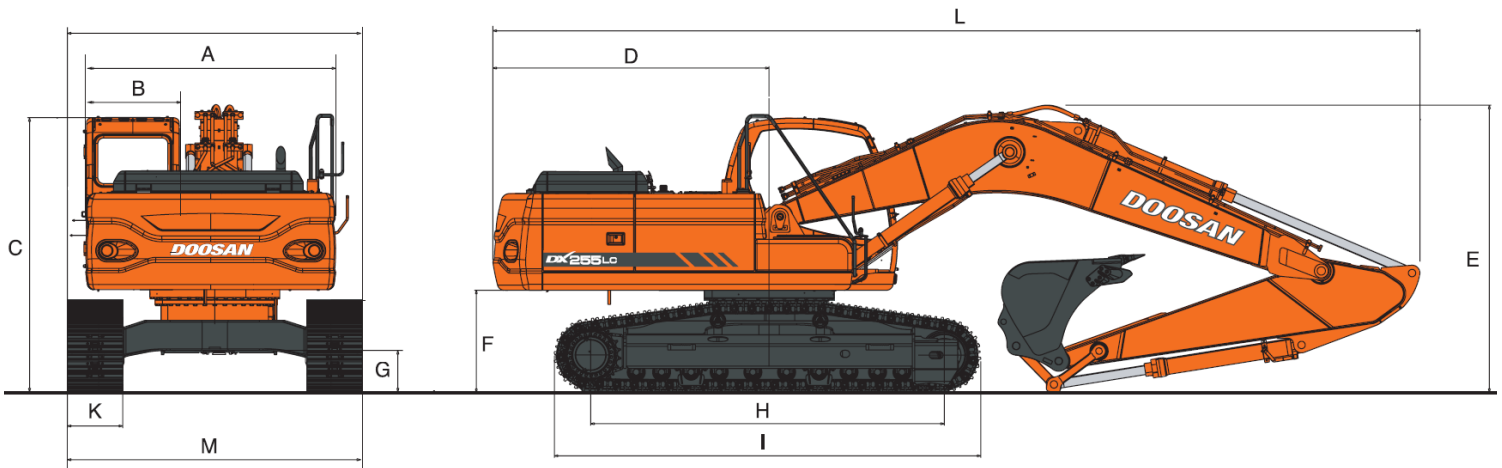

## Working Ranges

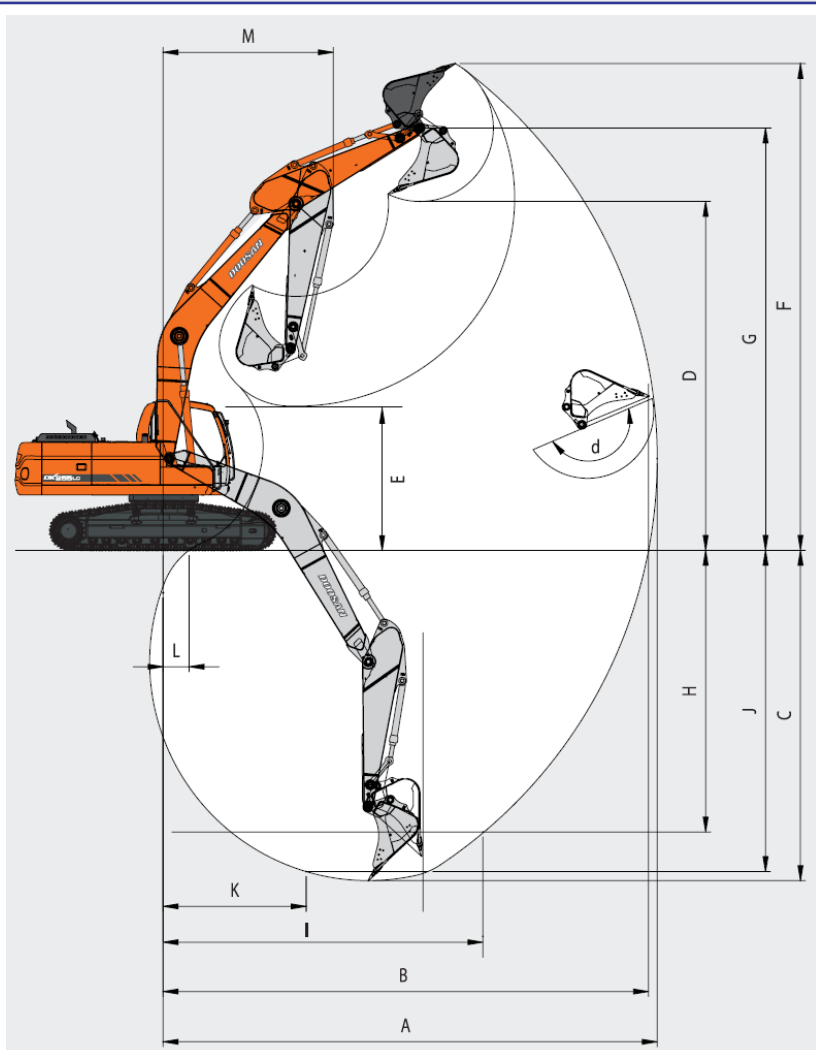

### All dimensions in millimetres

(A) Max digging reach	10195
(B) Max. reach on ground level	10010
(C) Max. digging depth	6815
(D) Max. dumping height	6925
(E) Min. dumping height	2530
(F) Max. digging height	9605
(G) Max. bucket pin height	8410
(H) Max. vertical wall height	5225
(I) Max. vertical radius	7230
(J) Max. digging depth (8' level)	6630
(K) Min. radius 8' line	2995
(L) Min. digging reach	600
(M) Max. swing radius	3845
(d) Bucket angle (degrees)	175°

### Quick Hitch

Geith Model 80

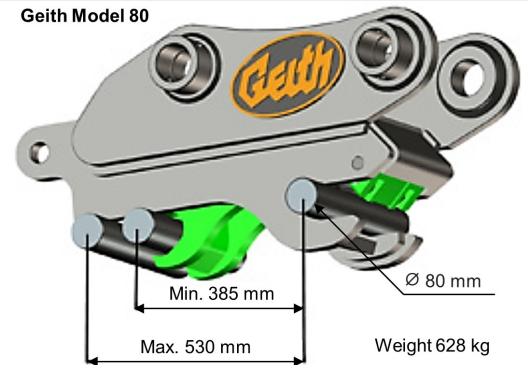

## Lifting Capacities

- Notes:
- The nominal forces are based on the SAE J1097 Standard.
  - The load point is the hook at the rear of the bucket.
  - \* Nominal loads are based on hydraulic capacity
  - The nominal loads do not exceed 87% of the hydraulic capacity or 75% of the capacity of the swing.
  - 0 m = Ground

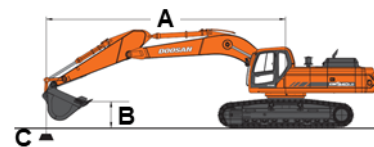

A: Load radius  
B: Load point height  
C: Lifting capacity

For lifting capacities, subtract quick-hitch, Movax attachment and any accessory weight from lifting capacities.



Rating over front



Rating side or 360 degrees

Unit : kg

Conditions	Load point height (m)	Load radius														Max. lift		
		2.0 m		3.0 m		4.0 m		5.0 m		6.0 m		7.0 m		8.0 m		metre		
		Rating over front	Rating side or 360 degrees	Rating over front	Rating side or 360 degrees	Rating over front	Rating side or 360 degrees	Rating over front	Rating side or 360 degrees	Rating over front	Rating side or 360 degrees	Rating over front	Rating side or 360 degrees					
Boom 5.9 m Arm 3.0 m	7.0											*4500	*4500			*3780	*3780	7.29
	6.0											*5100	5030			*3790	*3790	7.90
	5.0								5560	5560	*5360	4960	*4970	3950	*3870	3660	8.35	
	4.0						6910	6910	6220	6220	*5770	4860	*5480	390	*4010	340	8.66	
	3.0			14390	14390	10140	10140	8130	8020	6980	6040	*6250	4740	*5780	3830	*4210	3230	8.85
	2.0			6790	6790	12120	10960	9330	7730	7750	5860	*6760	4630	5710	3750	*4480	3150	8.91
	1.0			5900	5900	13530	10550	10320	7480	8420	570	6950	4520	5640	3690	4810	3140	8.87
	0	*3580	3580	7220	7220	14270	10350	10980	7320	8730	5580	6860	4440	5580	3640	4910	320	8.70
	-1.0	*6230	*6230	9.35	9350	14460	10270	11290	7230	8650	5510	680	4390	5550	3610	5150	3350	8.42
	-2.0	*8800	*8800	12040	12040	14200	10270	11250	7210	8620	5480	6780	4370			5560	3610	8.00
	-3.0	*11630	*15340	15400	15400	13510	10330	10830	7240	8640	550	6810	440			6250	4050	7.42
	-4.0	*14970	*18260	15660	15660	12310	10460	9940	7320	8100	5570					*7040	4830	6.63
-5.0		*22580	13010	13010	10360	10360	8300	7480							*7220	6390	5.56	

## Attachments

### Movax SG-50

Weight (excl. adapter)	2723 - 2558 kg
Width	1193 mm
Height	2478 mm
Depth	1180 - 1436 mm
Centrifugal force. Max.	500 kN
Eccentric moment	5.1 kgm
Engine power Min.	125 kW
Frequency	2300 - 3000 rpm
Pressure Setting	350 Bar
Return pressure. Max	5 Bar
Swing angle	+/- 360°
Tilt angle	+/- 30°
Clearance to centre line of pile	800 mm

### Suitable Pile Types & Dimensions

Sheet pile (width)	400 - 1200 mm
Sheet pile (depth)	265 mm
H-beam minimum size	H180 - H500
Timber pile	Ø 160 - 420 mm
Tubular pile, tubes	Up to 762 mm



Length & Weight	8 m / 2300 kg
	12 m / 1600 kg
	16 m / 1200 kg

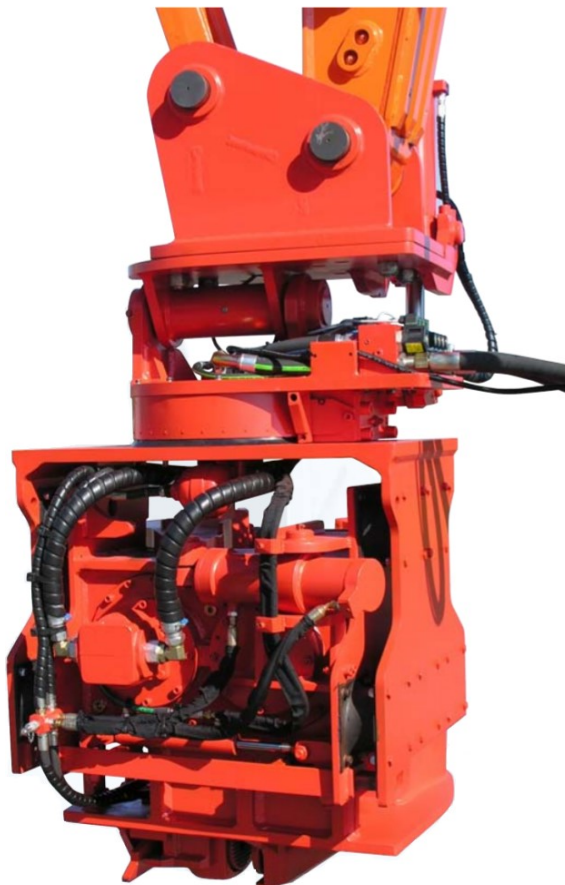

### Movax SP-50

Weight (excl. adapter)	1850 kg
Width	972 mm
Height	2071 mm
Depth	1224 mm
Centrifugal force. Max.	500 kN
Frequency	3000 rpm
Pressure Setting	320 Bar
Return pressure. Max	5 Bar
Swing angle	+/- 360°
Tilt angle	+/- 30°
Clearance to centre line of pile	800 mm

### Suitable Pile Types & Dimensions

Sheet pile (width)	600 - 1200 mm
Sheet pile (depth)	210 mm
H-beam minimum size	H240
Tubular piles (sizes) [tubular pile clamps fitted to sheet piler's clamps required]	Ø220, Ø200, Ø190, Ø170, Ø140, Ø115,



Length & Weight of pile	< 8 m / 800 kg
	> 8m / 1200 kg

## Accessories

ABI Dangle Drill	BA2200
Height (H1)	1390 mm
Height (H2)	1205 mm
Width (B)	710 mm
Depth (T)	540 mm
Transport Weight	700 kg
Torque	2200 daNm
Revolutions (max.)	50 per min <sup>-1</sup>
Static extraction force (max.)	200 kN
Hydraulic flow rate	220 l/min
Hydraulic power at auger drive (max.)	60 kW
Nominal oil pressure	32 MPa
Hexagon connection (SW - Z socket/male)	80 mm

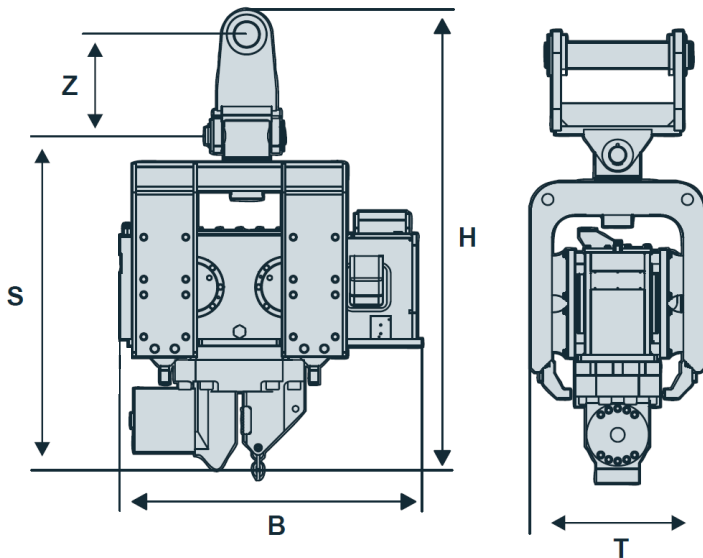
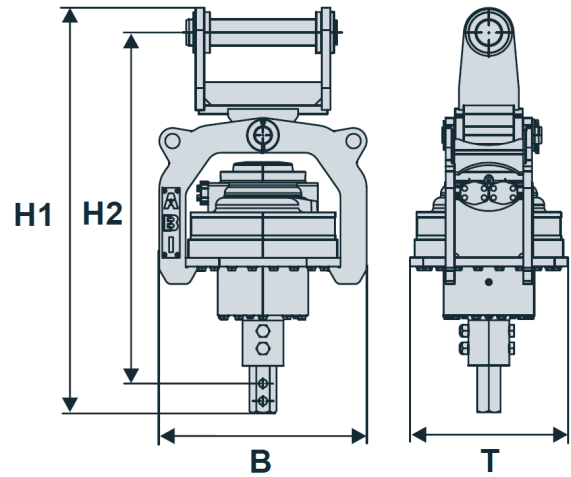

ABI Vibrator	HVR45
Height (H)	1600 mm
Width (B)	1065 mm
Depth (T)	615 mm
S	1160 mm
Z	352 mm
Static moment	4.5 kgm
Dynamic mass	815 kg
Nominal revolutions	2460 per min <sup>-1</sup>
Centrifugal force at nominal frequency	300 kN
Static extraction force (max.)	40 kN
Nominal oil pressure	32 MPa
Hydraulic flow rate	130 l/min
Hydraulic power at pmax <sup>a</sup>	70 kW
Total weight	1160 kg
Transport weight	1240 kg

<sup>a</sup> pmax = actual pump pressure at maximum power

BSP Air Hammer	600N	700N
Weight of ram	227 kg	385 kg
Stroke of ram	305 mm	330 mm
Energy per blow (max.)	415 kg/m	281 kg/m
Blows per minute (max.)	250	225
Recommended compressor	10.3 m <sup>3</sup> /min	17 m <sup>3</sup> /min
Weight of basic hammer with legs	2177 kg	3006 kg
(A) Overall height (Z section pairs, U section singles)	2273 mm	2419 mm
(A) Overall height (Z section singles, U section pairs)	2184 mm	2261 mm
(B) Depth of cylinder	508 mm	610 mm
(C) Anvil to base guide leg	900 mm	900 mm

