

# **BROCHURE**

## **THW 4019-D DRILLING RIG**

**[WWW.WOLTMANBV.COM](http://WWW.WOLTMANBV.COM)**



FOUNDATION RIGS AND CRAWLER CRANES

# THW 4019-D

## GENERAL INFORMATION

The THW 4019-D is a compact drilling rig with a total weight of 50 tonnes including a rotary head. The standard rotary head on a THW 4019-D is a WG-15 (15 TM), which can be used for both CFA and displacement piles. It's excellent mobility enables the THW 4019-D to complete several small jobs on one day, but also bigger projects are no problem.

## UNDERCARRIAGE

The THW 4019-D has a D6 undercarriage (H-shaped construction) with BERCO trackparts. The undercarriage can be hydraulically extended from a transport width of 3.300 mm to a operating width of 4.200 mm and the width of the 3-rib trackplates is 900 mm. Each trackframe can be extended separately. The undercarriage is driven by LOHMANN Planetary Gears.

## LEADER

The fully closed leader of the THW 4019-D has a standard length of 21,8 metres and the main dimensions are 600 x 500 mm. For drilling up to 22 metres length a 3 metre leader extension can be delivered with the machine as an option, so the total leader length will reach 24,8 metres.

The leader is suited for a maximum torque of 15 TM over it's full length and the maximum extraction force over the leader head is 40 tonnes. The leader is also fitted with a leader head, which has an extendable arm for the service winch (a second arm is optional). In order to reduce the transport length of the machine a hydraulic folding system will be fitted on the leader.

## ENGINE AND HYDRAULIC SYSTEM

The power unit comprises a CATERPILLAR C-12 DIT ATAAC diesel engine (TIER 2) producing 440 Hp (323 Kw) at 2100 Rpm with three Rexroth hydraulic pumps and REXROTH valve blocks. The hydraulic system is "Open Loop". Control of the rig is by means of hydraulically operated joysticks in the operator's cabin. When required the hydraulic system can be filled with biodegradable oil (option).

## WINCHES

The THW 4019-D is equipped with the following winches :

WINCH TYPE	LINE-PULL	SPEED	PARTS	DRUM	ROPE
Main winch	10,0 tonnes	0-60 mtr/min.	4	LEBUS	22 mm
Pull-down	6,0 tonnes	0-15 mtr/min.	1	Standard	19 mm
Service winch	3,0 tonnes	0-30 mtr/min.	1	Compl. winch	14 mm
Casting winch (option)	1,2 tonnes	0-30 mtr/min.	1	Compl. winch	10 mm



FOUNDATION RIGS AND CRAWLER CRANES

## CABINS AND OTHER SPECIFICATIONS

The operator's cabin of the THW 4019-D has enough room and will be arranged ergonomically. The operator's seat is of a good quality and has built-in joysticks for controlling the rig.

Standard control of the rig is by means of hydraulic joysticks (electric control is optional). All instruments in the operator's cabin are easy to oversee and the standard equipment consists of :

- An Inclinator
- A MFA-system for monitoring temperatures, pressures and tank contents
- A Blaupunkt Radio/CD player
- An adjustable heating system (Airconditioning is optional)

The engine compartments are easily accessible and also easy to dismount. In order to reduce the engine noise, all cabin parts will be fitted with sound isolating foam. All cabins will also be fitted with inner illumination and on the outside of the rig several working lights will be mounted. The complete rig will be painted in your company colours.

The THW 4019-D has a sliding brace with a stroke of 1.500 mm for spotting on the pile position. The counterweight is fixed and in the counterweight two outriggers have been mounted. Optionally the THW 4019-D can be fitted with two swingable front outriggers. With the help of the rear outriggers and the leader (or front outriggers) the machine can be lifted off the ground and the undercarriage can be freely rotated. This makes the loading of the THW 4019-D on a low loader a lot easier.



FOUNDATION RIGS AND CRAWLER CRANES

## TECHNICAL SPECIFICATIONS THW 4019-D AND WG-15

### THW 4019-D DRILLING RIG

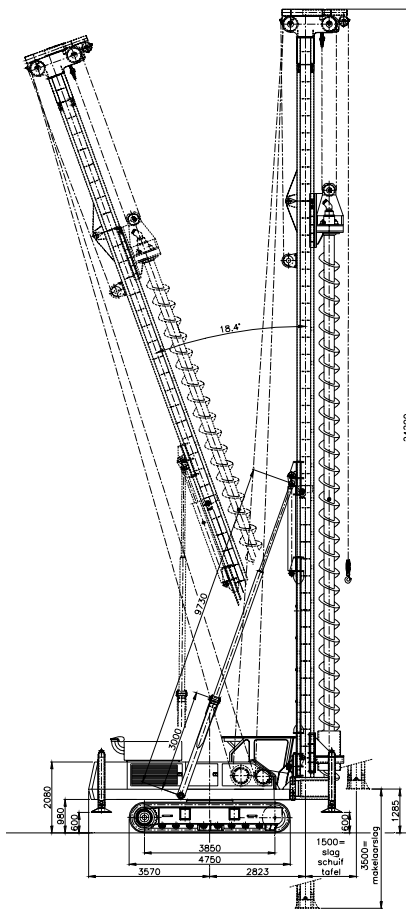

Standard leader length	: 21,80 metres
Maximum leader length	: 24,80 metres
Main dimensions of leader	: 600 x 500 mm
Stroke of leader	: 3.500 mm
Stroke of spotting device	: 1.500 mm
Capacity of main winch	: 10,0 tonnes
Speed of main winch	: 0-40 mtr/min.
Capacity of pull-down winch	: 6,0 tonnes
Speed of pull-down winch	: 0-15 mtr/min.
Capacity of service winch	: 3,0 tonnes
Speed of service winch	: 0-30 mtr/min.
Dieselengine	: CATERPILLAR
Engine power	: 440 hp at 2100 rpm
Hydraulic pumps	: Rexroth plunger
Valve blocks	: Rexroth
Electric system	: 24 Vdc
Trackparts	: BERCO
Type of undercarriage	: D6
Transport length (folded)	: 18.000 mm
Transport height (with WG-15)	: 3.500 mm
Transport width	: 3.300 mm
Operating width	: 4.200 mm
Length of undercarriage	: 4.750 mm
Standard trackplate width	: 900 mm
Counterweight	: 5,4 tonnes
Machineweight with WG-15	: 50 tonnes

### THW WG-15 ROTARY HEAD

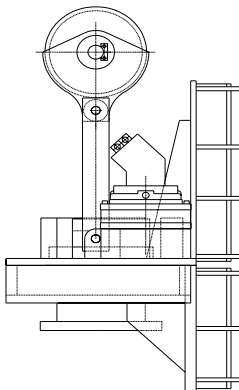

Maximaal torque	: 15 TM
Maximum speed without load	: 0-26 Rpm
Output shaft	: 350 mm
Maximum working pressure	: 300 Bar
Maximum oilflow	: 520 Ltr/min.
Height	: 1.575 mm
Depth	: 1.058 mm
Width	: 1.281 mm
Minimum stand off	: 450 mm
Weight WG-15	: 3.400 kg



FOUNDATION RIGS AND CRAWLER CRANES

# THW 4019-D

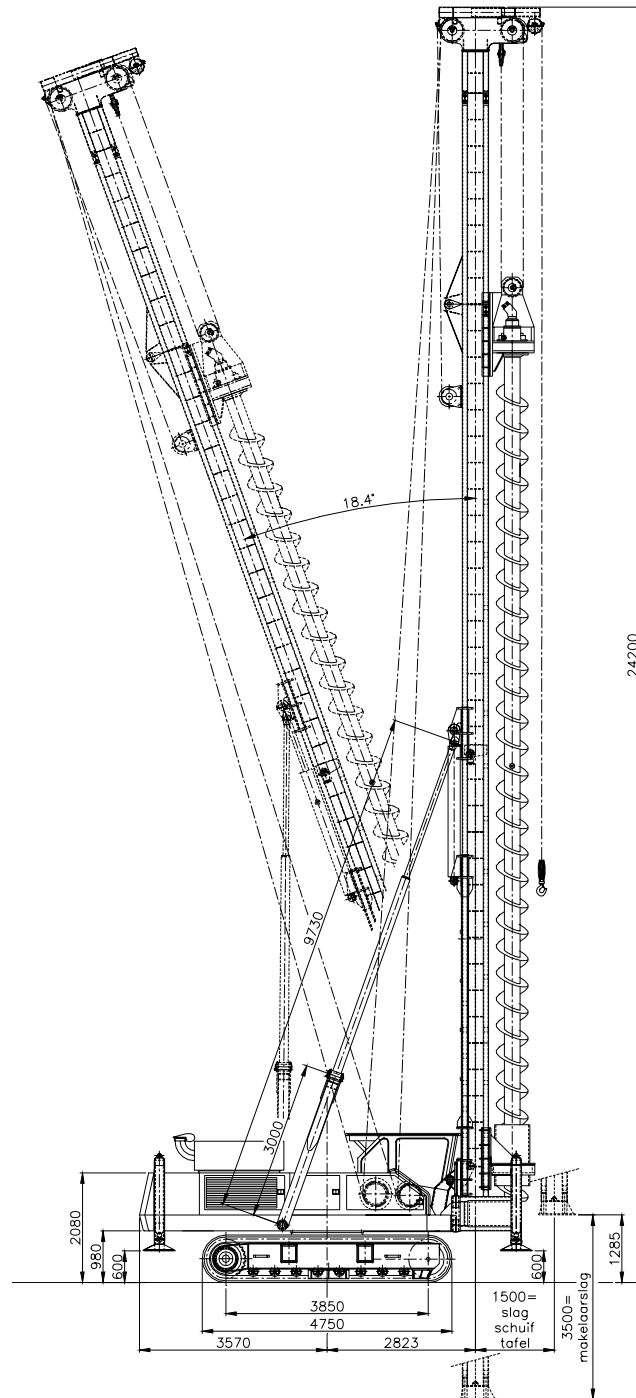



# THW 4019-D

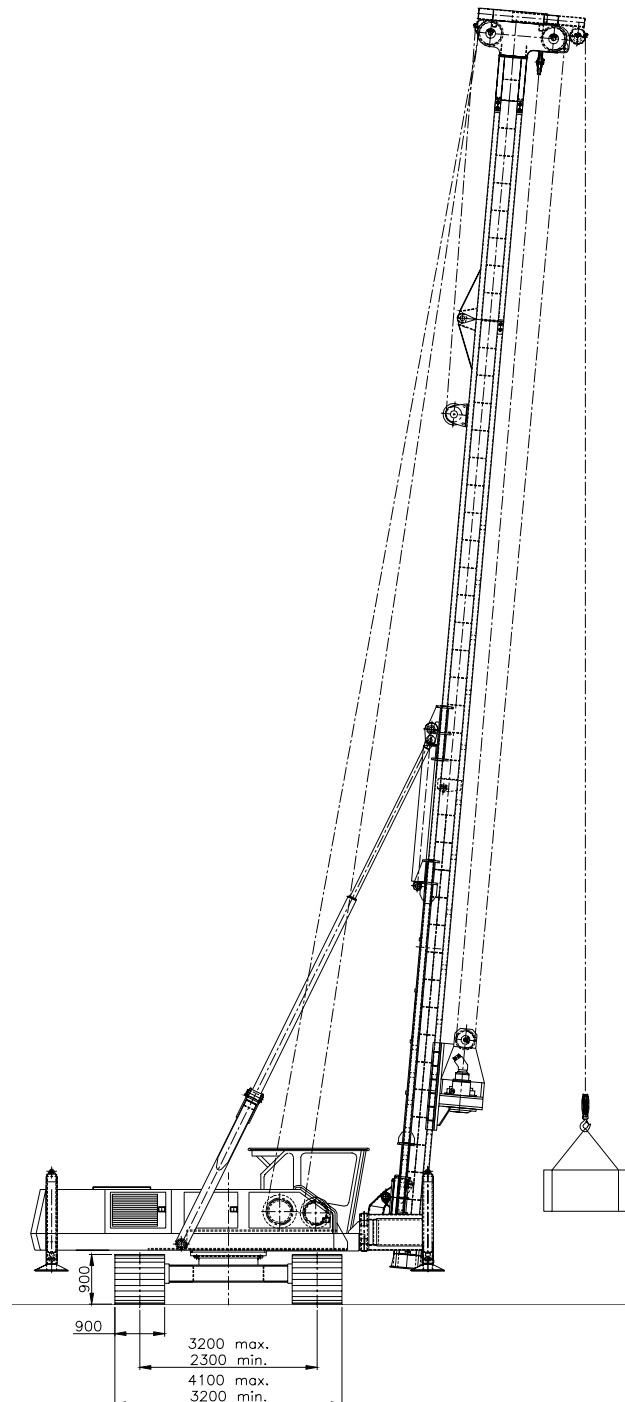



FOUNDATION RIGS AND CRAWLER CRANES

# THW 4019-D

